



TYPE _____

CATALOG# _____

LED Exit Emergency Combo (EEU-MR)

LIGHT STYLE™ SERIES



EEU-MR

Dimensions

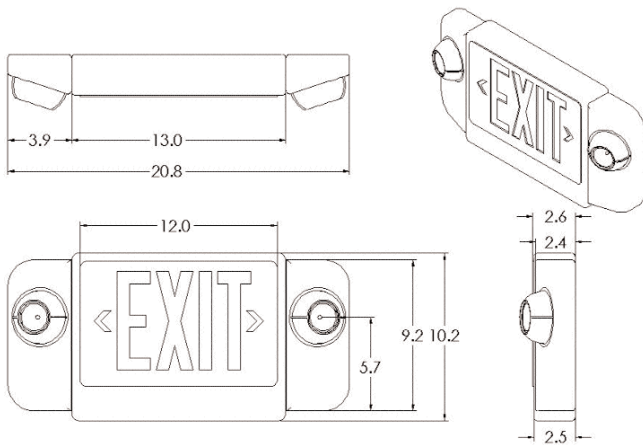

Applications

Commercial, retail, and industrial facilities that require exit lighting and emergency lighting with maximum glare free illumination and years of maintenance free operation.

Standard Features

- 120 or 277 VAC input.
- Energy consumption of less than 4.5 watts for red letters and green letters.
- LED lamp life of 10 years.
- Completely self-contained.
- Universal mounting canopy for top installation.
- Installs in minutes with only a screwdriver.
- Two fully adjustable, glare-free lighting heads with 7 watt MR16 Halogen lamps standard.
- Injection-molded, high impact, thermoplastic housing.
- Universal snap in and out chevron meets all state and local codes.
- Includes downlight.
- Damp location listed to UL 924
- Remote Capability
- ETL Listed

Operation

The LED exit sign is illuminated by normal AC power. When normal AC power fails, the solid state transfer switch connects the battery to the LED lamps to keep the exit sign lit for 1-1/2 hours. At the same time, battery power is supplied to the two lamp heads, lighting a path of egress for no less than 1-1/2 hours.

When AC power is restored, the battery is recharged by the solid state charger within 24 hours.

Warranty

Both the fixture and battery carry a warranty for a period of 5 year to be free from defective material and workmanship. The battery is pro-rated for a 5-year period when operated at recommended ambient temperatures.

EEU-MR

Model

—

Letter Color

R Red
G Green

—

Housing Color

W White

—

Factory Installed Options

REM Remote Capable
MAX 6V 10W

