



EU-3-Plus
Up To 30 Watts At 6 Volts
Heavy Duty Remote Capable
Emergency Battery Unit

COMMERCIAL SERIES



EU-3-Plus

Wall Mount

Dimensions in Inches

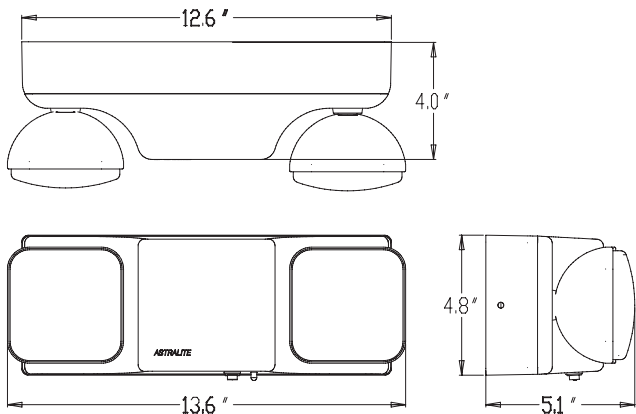

*Note: To determine Maximum Remote Wattage, Subtract total integral lamp Watts from total DC Unit Wattage.
 Example: 22 Watts Unit (Total DC Wattage) minus 14.4 Watts (2 X 7.2 Watt Lamps) Equals 7.6W Watts Maximum available for remote lamps. So this Unit can run an additional remote 7.2 W Lamp

GENERAL DESCRIPTION

Redefining the aesthetic standards the industry has settled for in the past, the EU-3-Plus emergency light packs the power you need with the same foot print as an regular low wattage unit. It is remote capability while offering the maximum performance of two fully adjustable lamp heads. This unit eliminates the need for the bulky lunch box versions of the past with a uniquely contoured thermo plastic housing that blends nicely in any environment.

HOUSING

UV Stable thermo- plastic flame retardant meets UL standard 95-VA. Standard white or black finish (matches all products in same family). Surface mount easy installation low profile design features two square Metal Reflector and Glass Diffuser fully adjustable heads. Damp location listed standard.

ILLUMINATION

Two High Intensity 5.4 watt lamps mounted in photometrically optimized precision formed reflector assemblies exceed illumination required by UL 924 with better space to mounting criteria than the industry standard incandescent offerings. The soft etched lens eliminates glare and striation often associated with prismatic spread lenses while providing even distribution along areas of egress.

ELECTRONICS & BATTERY

Dual Transformer input Voltage (120/277 VAC) Powers the fully automatic Solid State charging system which features (LVD) Low Voltage Disconnect, AC lockout installation and brown out protection and AC indicator LED light standard. The maintenance free Sealed Lead Calcium battery provides a minimum of 90 minutes of illumination in emergency mode with an average life of 5 years. Optional Nickel Cadmium battery also available.

CODE COMPLIANCE

Tested and Listed to UL 924 Damp location. Meets or exceeds NFPA NEC and OSHA illumination standards.

WARRANTY

5 years on housing and electronics with a 5 year pro rated warranty on battery.

EU-3-Plus				
Model	Total DC Watts / Battery Type	Integral Lamps	Housing Color	Factory Installed Options
	22 Watts Sealed Led 30 Watts Sealed Led 16 Watts Nicad 25 Watts Nicad	-5 (2) 5.4 W wedge -7 (2) 7.2 W wedge -9 (2) 9.0 W wedge -10* (2) 10 W Bi-Pin *Halogen * Contact factory for others lamps	W White B Black	220 220/230 VAC Input *A Ammeter *V Voltmeter SD Self Diagnostics CP Canopy **TD Time Delay Note: * Select one ** TD Must Specify AC Input Voltage and Delay Time in Minutes.

