



TYPE _____

CATALOG# _____

DC-AP

HEAVY DUTY OUTDOOR/INDOOR DIE CAST EMERGENCY UNIT

GENERAL DESCRIPTION

The Astra Path Series emergency unit is available in an array of different finishes that allows itself and the rest of this family of high-end emergency products to accentuate any custom interior design.

HOUSING

Die cast aluminum construction with powder-coated finish provides style and durability for any application.

ILLUMINATION

Two 6 volt, 6 Watt Integral bi-pin xenon lamps (standard) provide more than 1fc in at least 2 points on floor (as required by UL 924) as well as superior color rendering capabilities. See options below or consult factory for specific requirements.

ELECTRONICS

Dual Voltage 120/277 VAC input facilitates the fully-automatic Solid State charging system which features Low Voltage Disconnect (LVD) , AC-lockout installation, brown-out protection, and Self-Diagnostic / Self-Testing. The maintenance-free sealed nickel-cadmium battery provides a minimum of 90 minutes of illumination in emergency mode with an average life of 7 years and comes standard in all Die Cast Astra Path fixtures. Wet Location (0°C ~ 50°C) and Self-Diagnostic / Self-Testing are standard.

CODE COMPLIANCE

Tested and Listed by ETL to meet UL 924 for wet location, meets or exceeds NFPA, NEC, and OSHA illumination standard.

WARRANTY

5 years on housing and electronics with a 7-year pro rated warranty on battery.

ARCHITECTURAL SERIES



DC AP

DIMENSIONS

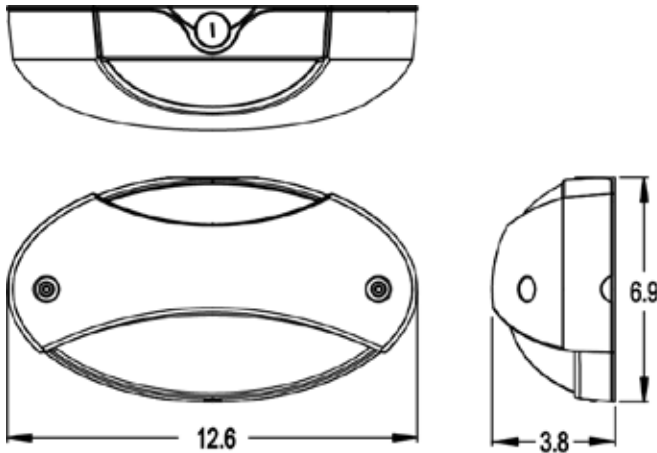

DC-AP

MODEL

HOUSING FINISH

FACTORY INSTALLED OPTIONS

BK* = BLACK
 WH = WHITE
 DB = DARK BRONZE
 SL = SILVER
 * STANDARD

C = COLD WEATHER (-18°C ~ 50°C)

NOTE: MAINTENANCE-FREE SEALED NICKEL-CADMIUM BATTERY AND SELF-DIAGNOSTICS/SELF-TESTING BOARDS STANDARD.

